

Ana Şanzıman Modeli
MERCEDES
G 131-9
G 141-9
G 211-12
G 211-16
G 221-9
G 230-12
G 230-16
G 240-16
G 260-16
G 280-16
G 281-12
G 330-12

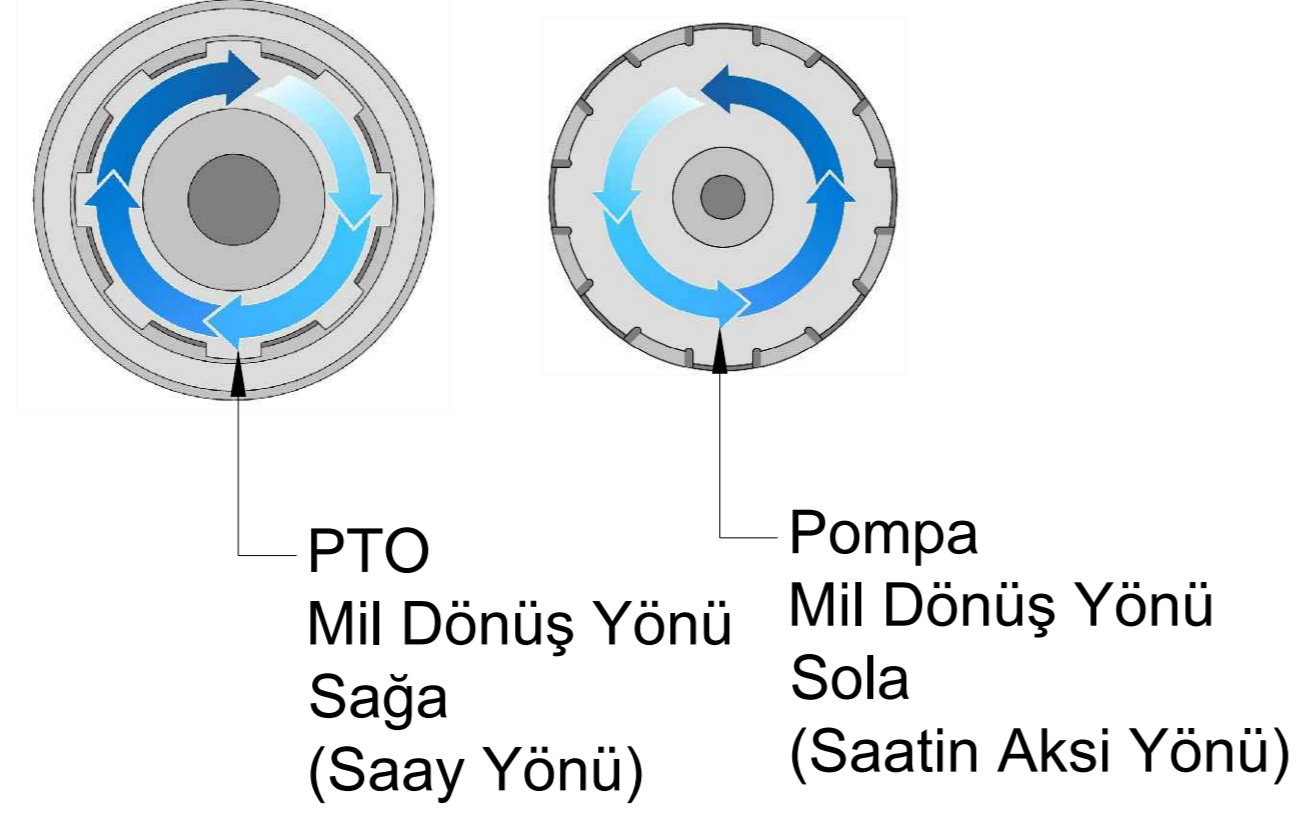

Ürün Kod Detayı	3	6	9	A	C	2	F
Kardan Millî							
Kare Flaşlı / ISO 14 / DIN 5462 / 8x32x36							
Akuple							
Havali							
Sıra No							

PTO'nun Teknik Özellikleri	
Kodu	369AC2F
Dişli Tipi	Düz
Tipi	Tek Dişli / Hava Yastıklı / Keçeli
Tork Nm	450
Güç Kw	47
Tahvil Oranı 1000 d/d	1:1,00
Bağlantı Yeri	Kuyruktan
Kontrol Sistemi	Havali
PTO Mil Dönüş yönü	Sağa (Saat Yönü)
Pompa Mil Dönüş Yönü	Sola ( Saatin Aksi Yönü)
Ağırlık Kg.	12,80

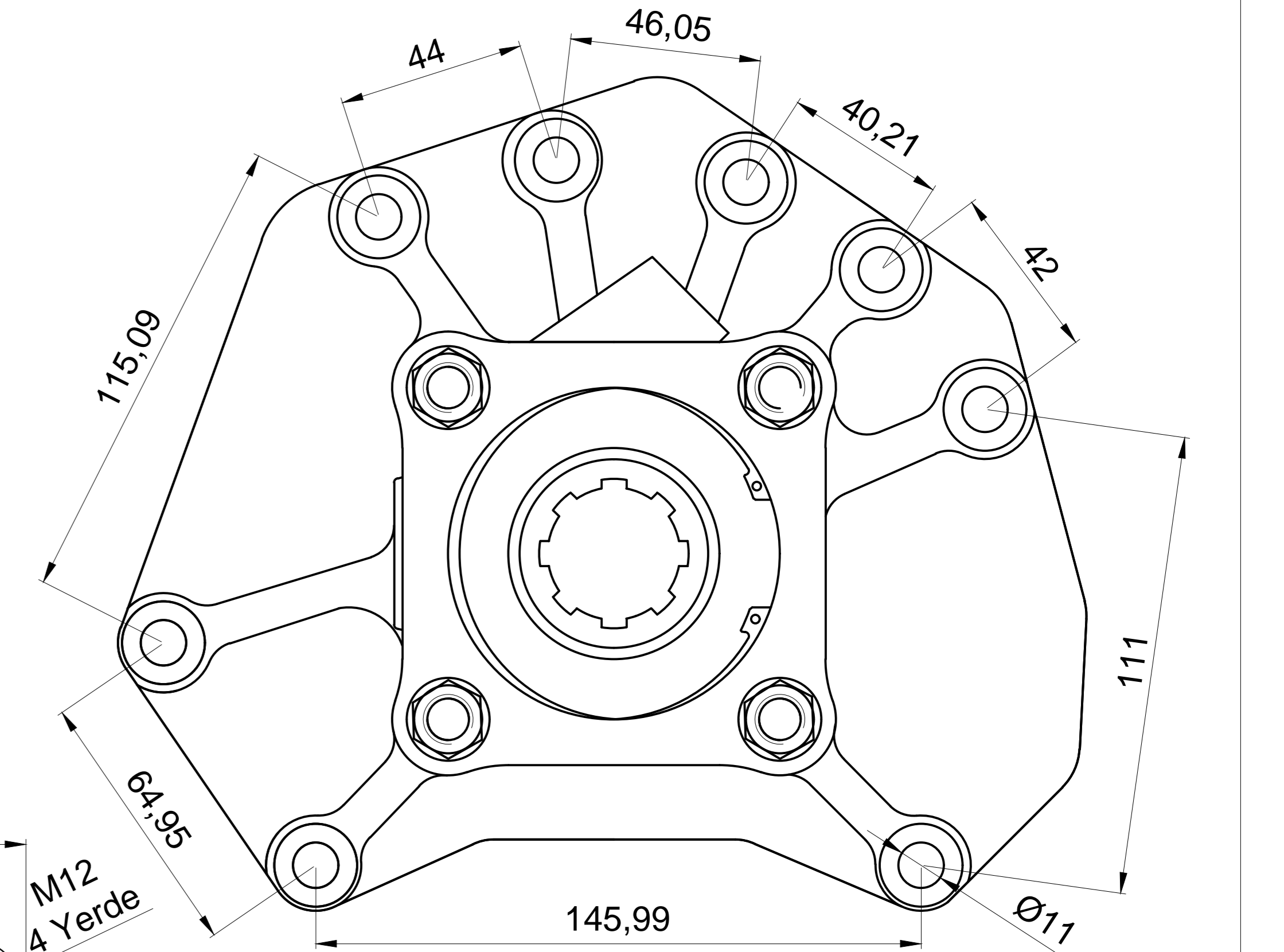
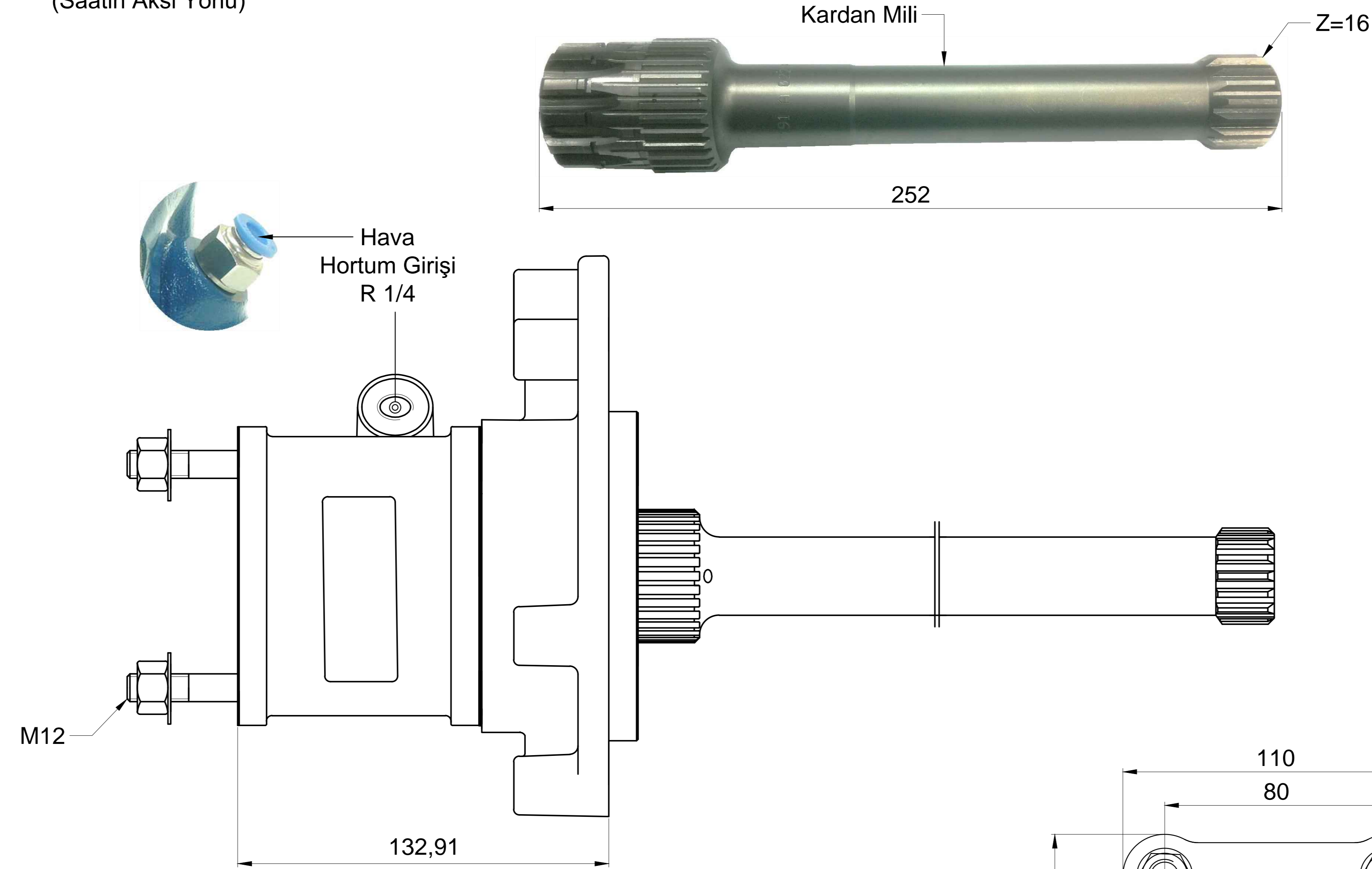
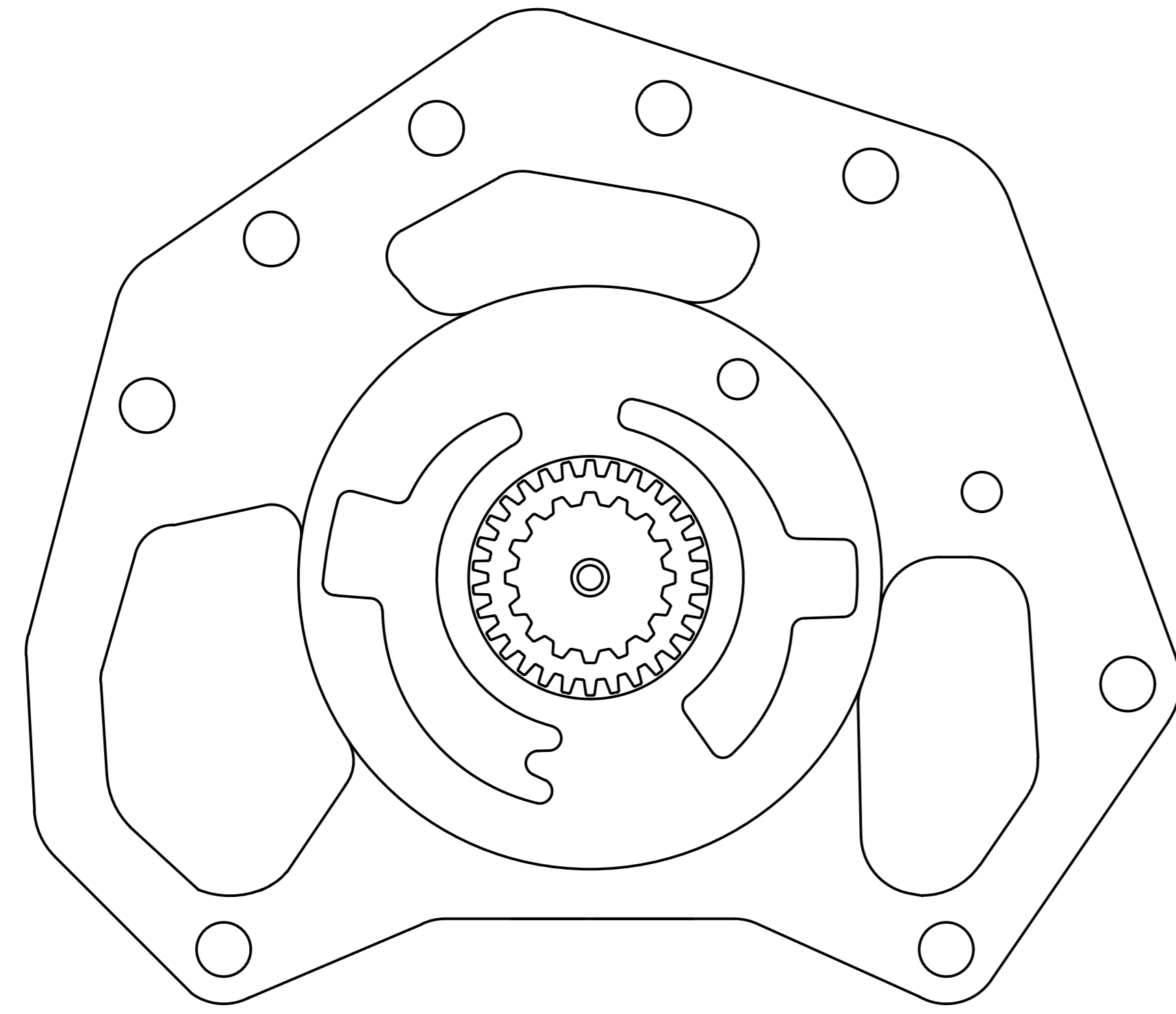

PTO Bağlantı Yeri  
Aracın Arka Tarafı  
(Kuyruktan)

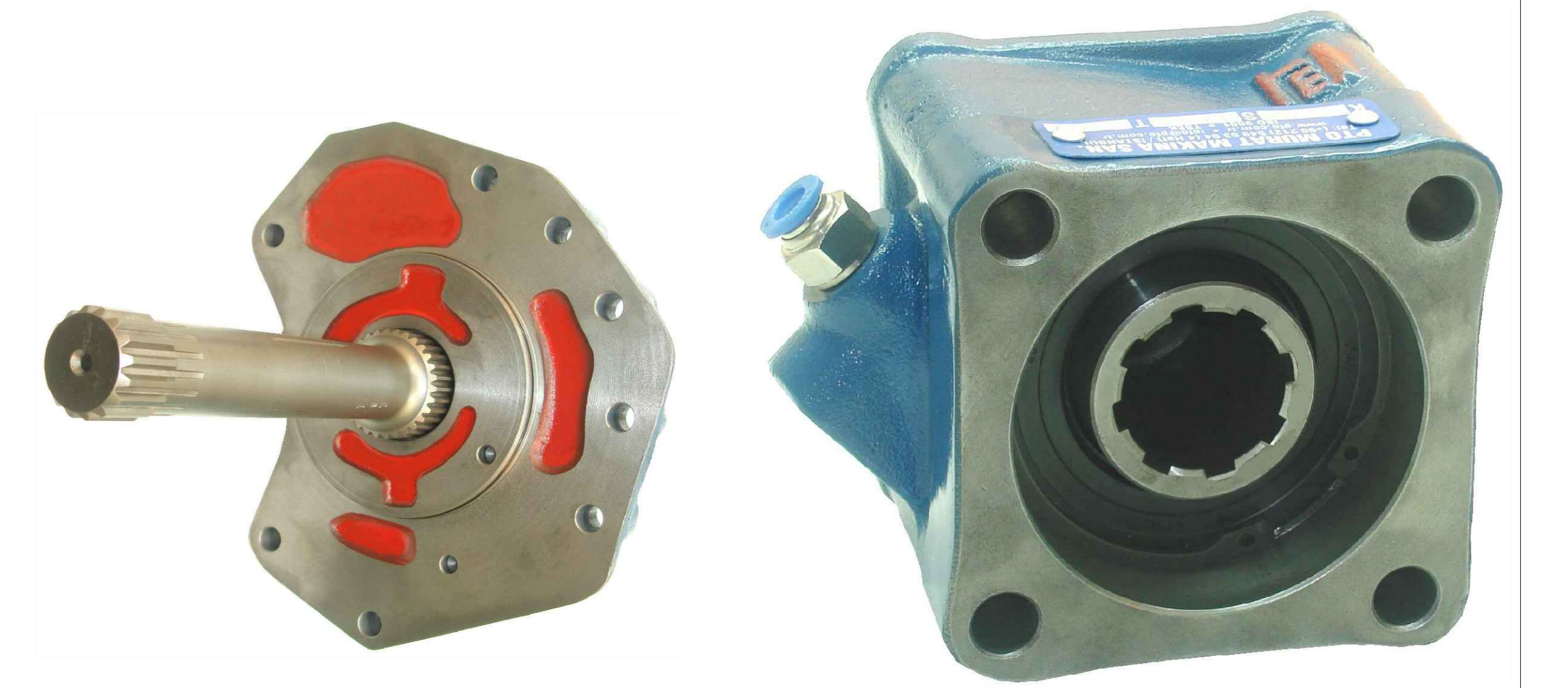
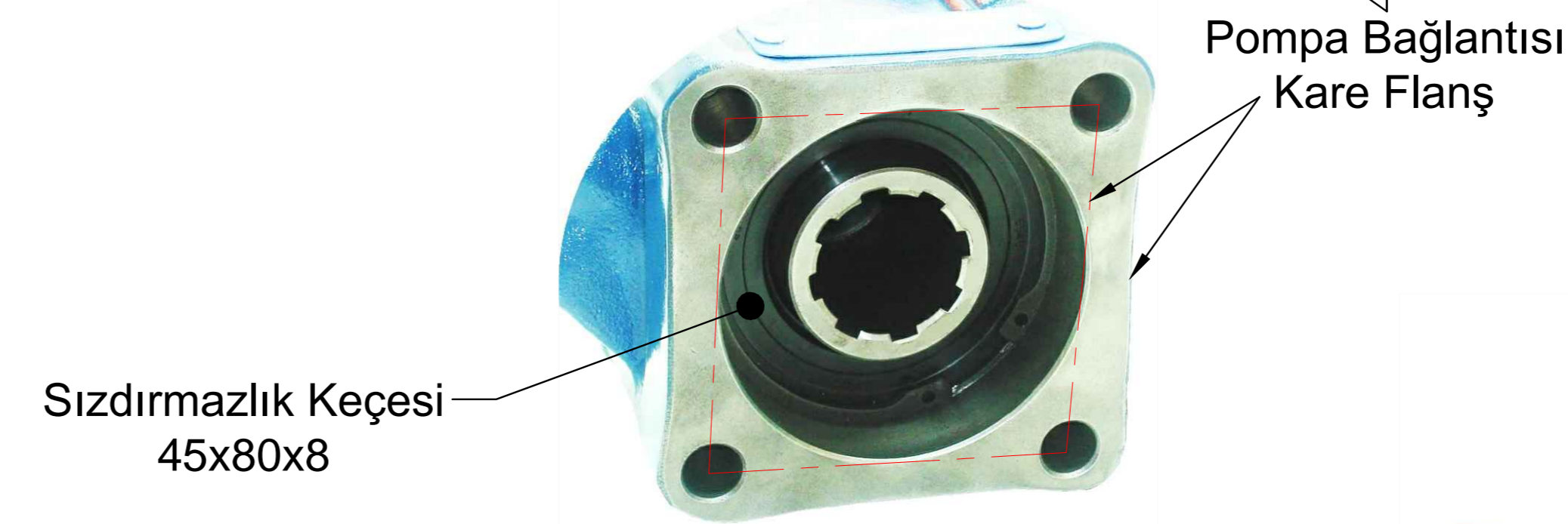

**PTO**  
Murat Makina  
San.Tic.Ltd.Şti.

www.pto.com.tr  
info@pto.com.tr

+90 212 549 53 04 Pbx  
+90 212 549 53 08 - 09  
+90 533 960 33 60  
+90 532 554 16 36  
ptomms  
Pto Murat Makine+  
@PTOMURATMAKINA  
+ikitelili Org.San.Bölg. Atatürk Bulv. Eskoop San.Sit. A2. Blok No.80 Başakşehir - İstanbul / TÜRKİYE